

**Dia.200mm (8inch) Red Green Countdown and Bicycle LED Traffic Light**  
**Suitable for actuated systems**

	<p><b>Model:</b> FJ200-3-25D - <u>*Suitable for actuated systems*</u></p> <p><b>Keywords:</b> Red, Green bicycle Signal Light, Bicycle Traffic Signal Light, Bicycle Signal Light, Bicycle Traffic light, 200mm led bicycle traffic light etc.</p> <p><b>Application:</b> Red, Green Bicycle Traffic Light is widely used in Bicycle Road to indicate whether cyclists can go or not.</p> <p><b>Strengths:</b> Good Visibility, Energy Saving, Low Thermal Energy, Long Life Span, Impact Resistance, Good Quality, Competitive Price.</p>
--	--

**Technical Parameters:**

Color	LED Q.ty	Light Intensity	Wave Length	Power Fact	Viewing Angle	Power	Working Voltage	Housing Material
Red Countdown	64pcs	≤320cd	625±5nm	>0.9	30°	≥4W	85V-265VAC	PC, UV Resistant
Green Countdown	64pcs	≤608cd	505±5nm			≥5W		
Red Bicycle	48pcs	≤240cd	625±5nm			≥3W		
Green Bicycle	48pcs	≤456cd	505±5nm			≥4W		

**Packing Info:**

Carton Size	Q'TY	GW	NW	Wrapper	Volume (CBM)
66*29*23cm	1pcs/carton	5.2kg	4.7kg	K=K Carton	0.04

**Packing List:**

Part name	Light	Bracket	Sun Visor	M4x10 Screw	M4x20 Screw	Wiring Box And Gasket	Using Manual	Certificate
Q'ty. (pcs)	1	2	2	8	4	1	0	0

**Dimension Figure:**

# Product Size

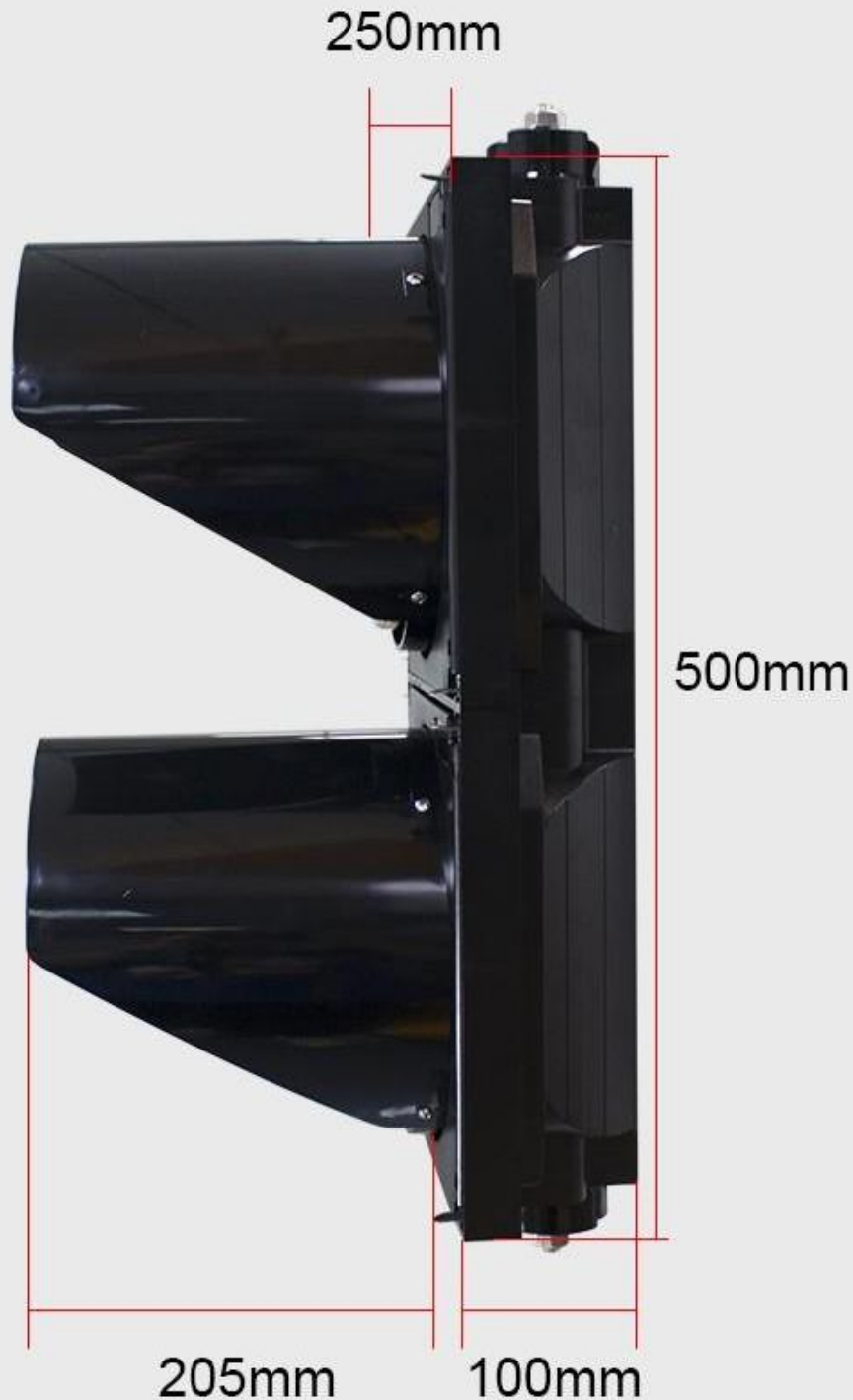

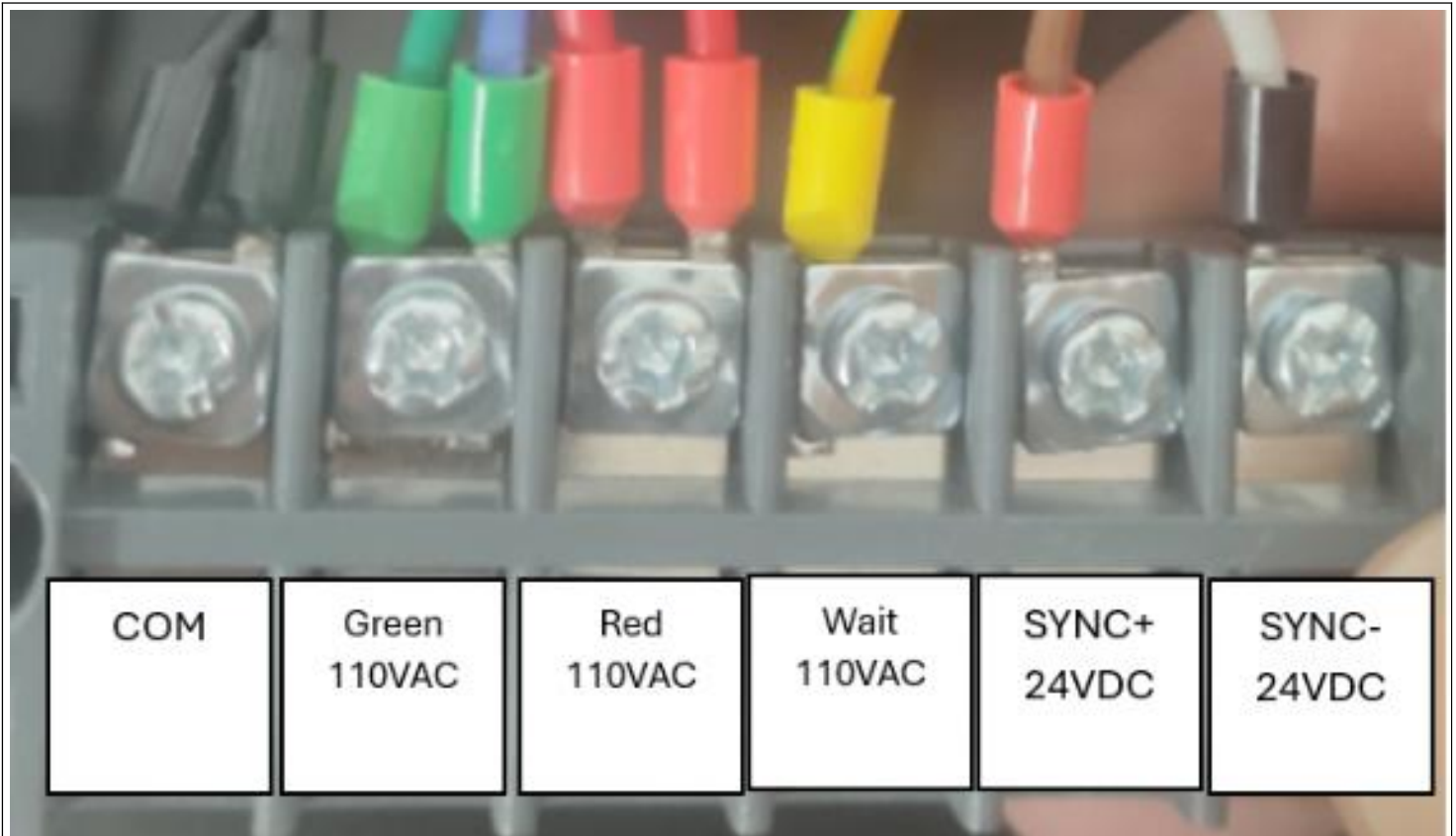
**Connection Sketch:****Key Features/Bullet Points:**

- LED:** Our LED lamp beads are UL Listed; each LED is imported from Taiwan. The LED life span up to 100000 hours. Red LED with 4000-5000mcd brightness, Green LED with 7000-9500mcd brightness. LED light-emitting diode is a light source, with stable performance and ideal display effect.
- BLACK HOUSING & WATERPROOF:** Durable black housing to ensure durability and a multilayer seal protects lens from dust and water seal to keep protected from water in harsh weather environments. The waterproof grade is IP65.
- CLEAR LENS & MODULES:** It's made of clear lens, High penetrability, Fire resistance, Anti-UV. The modules' diameter is about 188 mm (8 inch).
- WORKING VOLTAGE & EASY INSTALLATION:** Operating voltage of DC9-36V or 85V-265VAC; Red light to R terminal, Green light to G terminal, common is public line.
- CERTIFICATE & WARRANTY:** It's got the FCC, CE, IP65, RoHS certifications. Two years warranty promise.



深圳市邦贝美科技有限公司  
SHENZHEN BBM TECHNOLOGY CO., LTD

---



Tel:(86)755 29174815

Fax:(86)755 29174811

[www.bbml.com](http://www.bbml.com)

Add: 2/F, The 7th Building, Country Garden Robot Industrial Park, Songgang Street, Baoan District, Shenzhen, Guangdong, China.